

120V USA

Masse/Dimensions in mm
2,8-3,3Nm

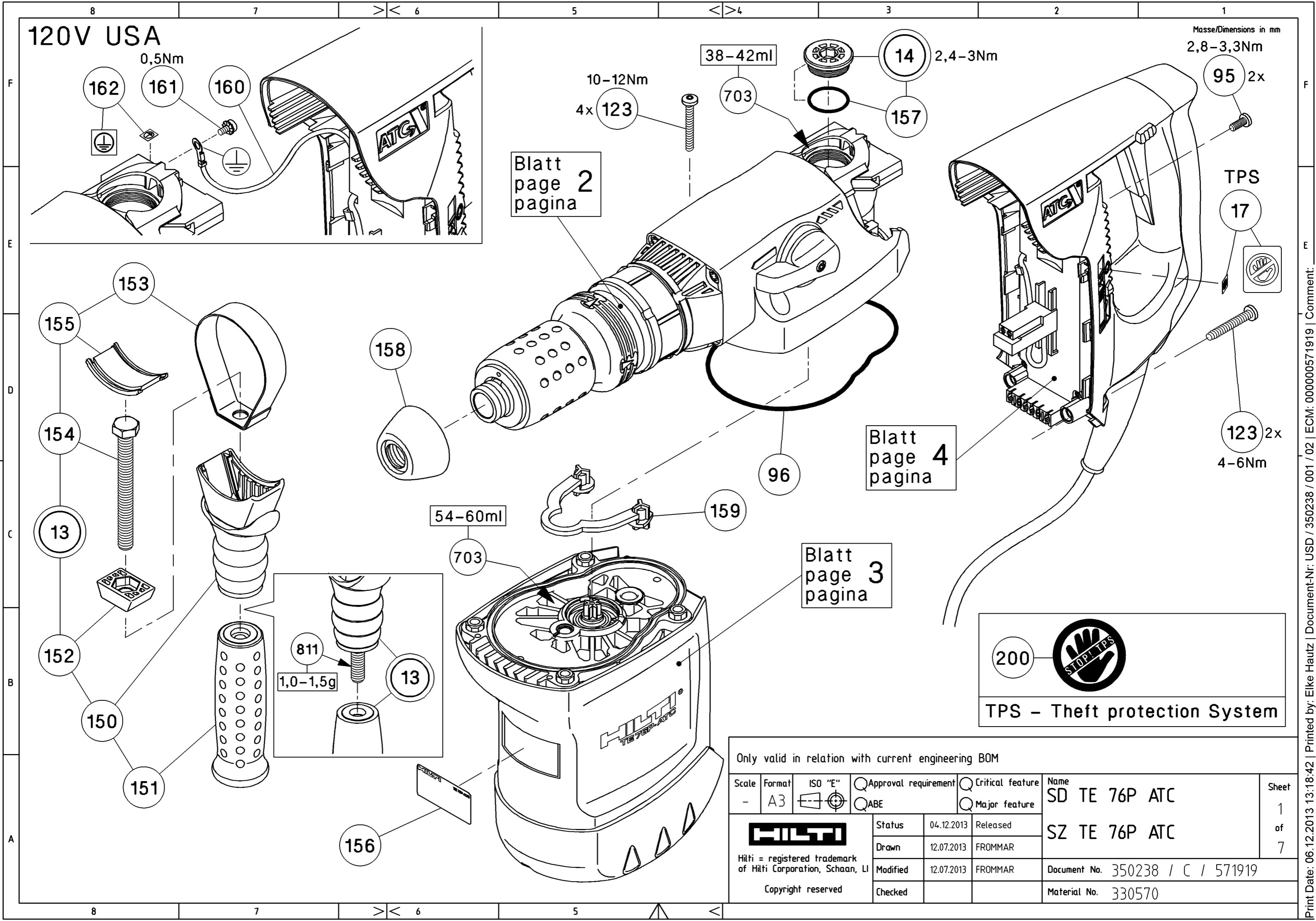

200 

TPS - Theft protection System

Only valid in relation with current engineering BOM

Scale	Format	ISO "E"	<input type="checkbox"/> Approval requirement	<input type="checkbox"/> Critical feature	Name	Sheet
-	A3		<input type="checkbox"/> ABE	<input type="checkbox"/> Major feature	SD TE 76P ATC	1
 Hilti = registered trademark of Hilti Corporation, Schaan, LI Copyright reserved					Status	04.12.2013 Released
					Drawn	12.07.2013 FROMMAR
					Modified	12.07.2013 FROMMAR
					Checked	
					SZ TE 76P ATC	of 7
					Document No. 350238 / C / 571919	
					Material No. 330570	

Print Date: 06.12.2013 13:18:42 | Printed by: Elke Hantz | Document-Nr: USD / 350238 / 001 / 02 | ECM: 00000571919 | Comment:

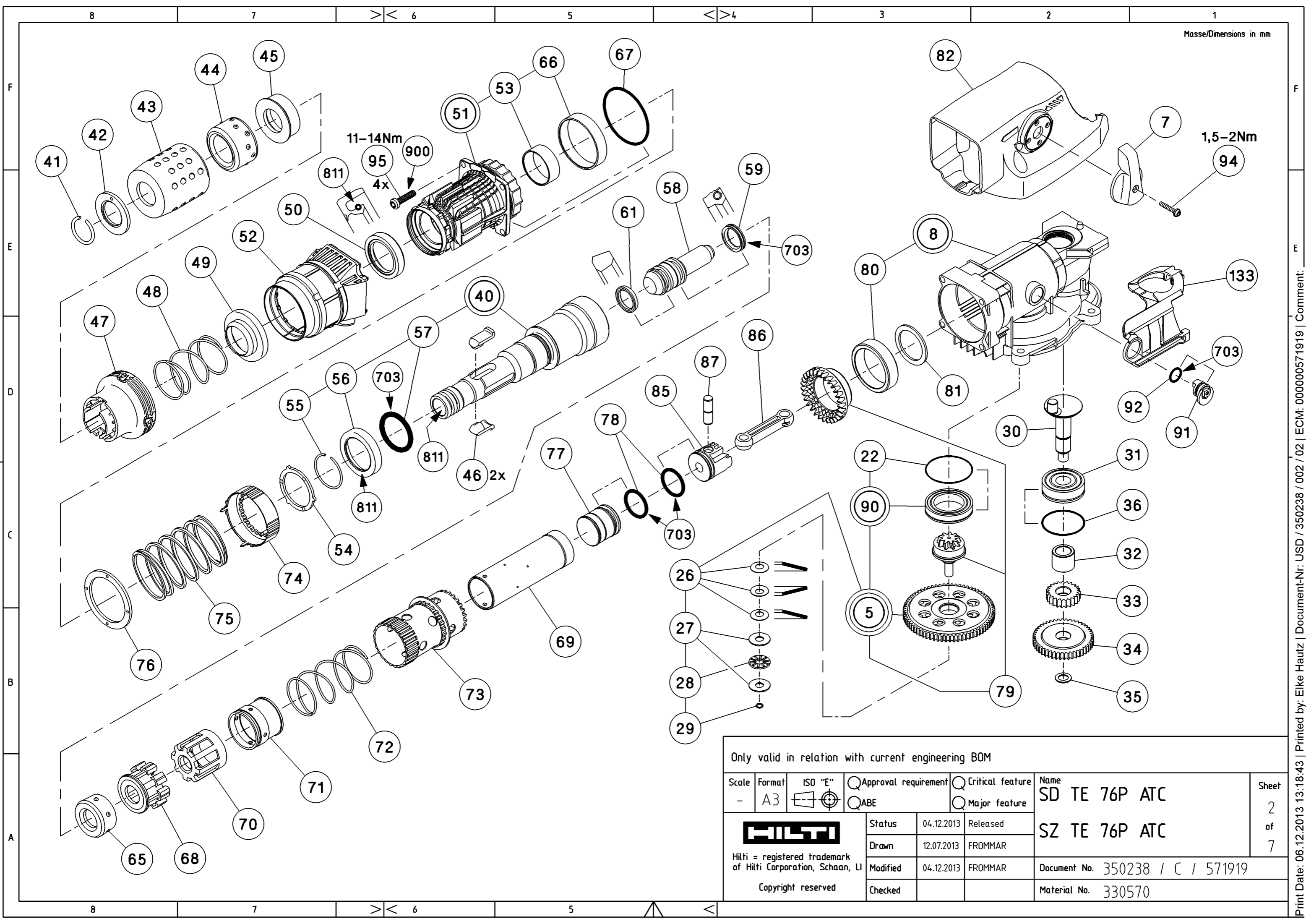

Only valid in relation with current engineering BOM

Scale	Format	ISO "E"	<input type="checkbox"/> Approval requirement	<input type="checkbox"/> Critical feature	Name	Sheet
-	A3		<input type="checkbox"/> ABE	<input type="checkbox"/> Major feature	SD TE 76P ATC	2
<p>Hilti = registered trademark of Hilti Corporation, Schaan, LI Copyright reserved</p>					Status	04.12.2013 Released
					Drawn	12.07.2013 FROMMAR
					Modified	04.12.2013 FROMMAR
					Checked	
					SZ TE 76P ATC	of 7
					Document No. 350238 / C / 571919	
					Material No. 330570	

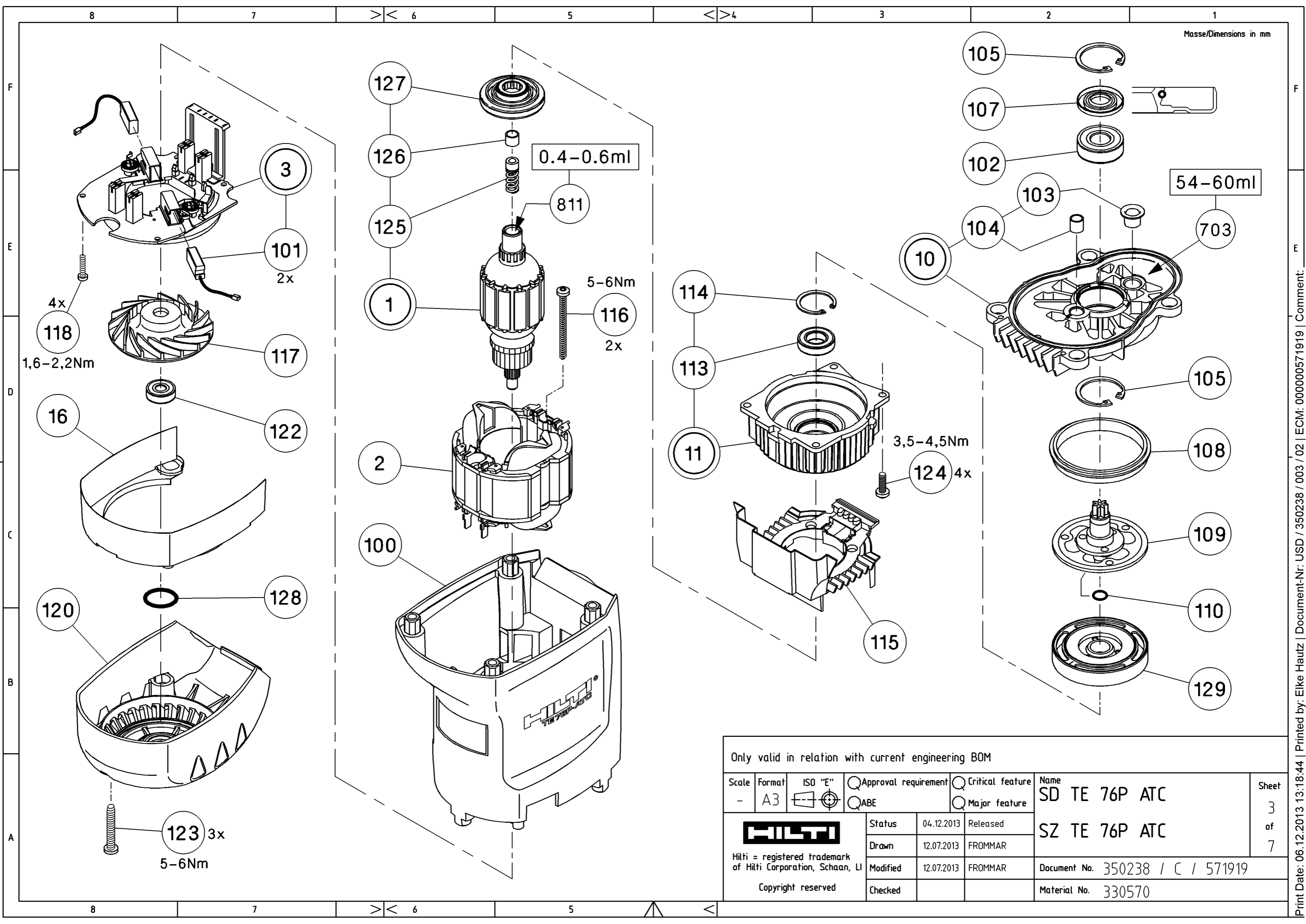

Masse/Dimensions in mm

Only valid in relation with current engineering BOM

Scale	Format	ISO "E"	<input type="checkbox"/> Approval requirement	<input type="checkbox"/> Critical feature	Name	Sheet	
-	A3		<input type="checkbox"/> ABE	<input type="checkbox"/> Major feature	SD TE 76P ATC	3	
 Hilti = registered trademark of Hilti Corporation, Schaan, LI Copyright reserved					Status	04.12.2013	Released
					Drawn	12.07.2013	FROMMAR
					Modified	12.07.2013	FROMMAR
					Checked		
					SZ TE 76P ATC		of 7
					Document No. 350238 / C / 571919		
					Material No. 330570		

Print Date: 06.12.2013 13:18:44 | Printed by: Elke Hantz | Document-Nr: USD / 350238 / 003 / 02 | ECM: 00000571919 | Comment:

120V USA

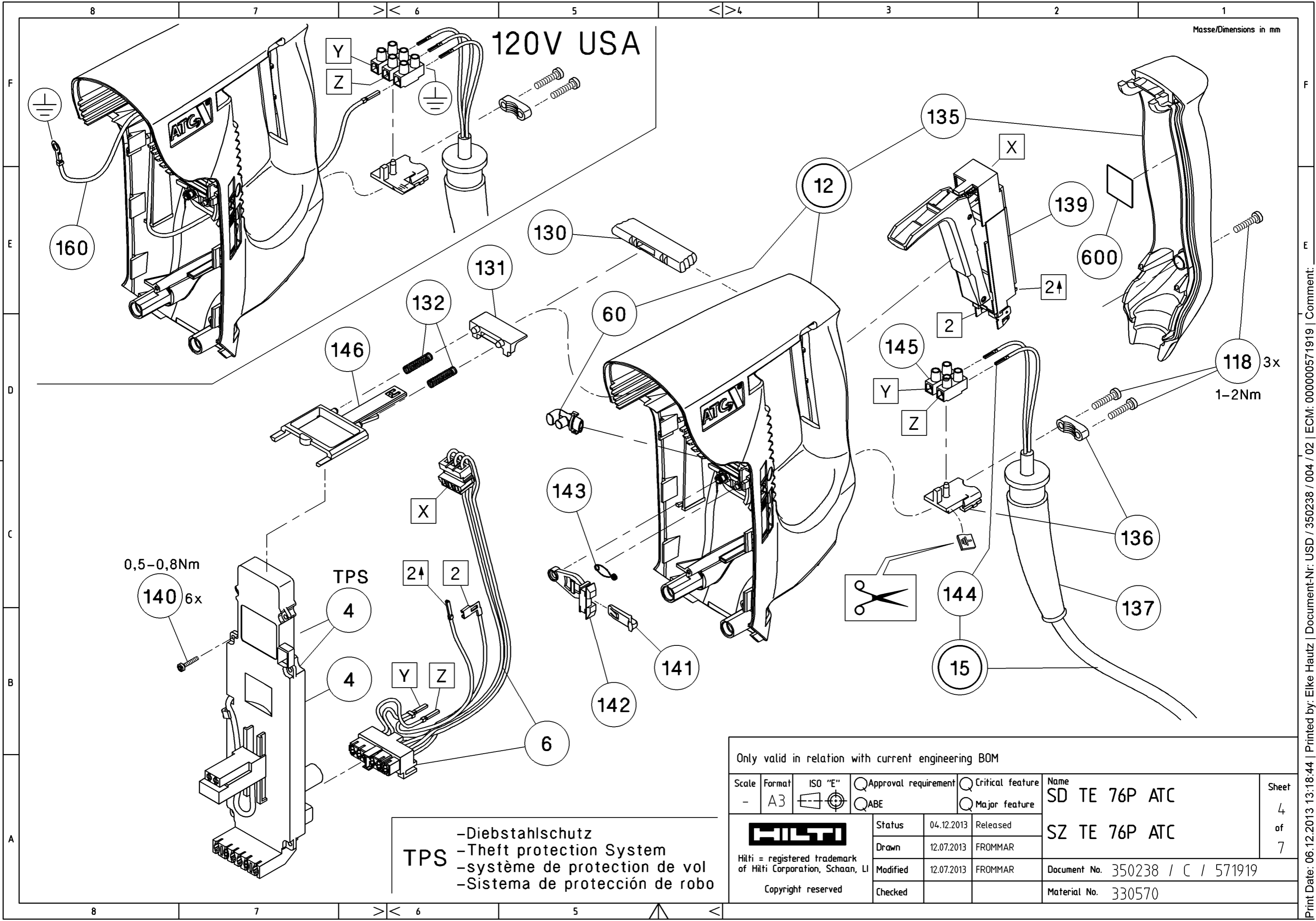

TPS
 -Diebstahlschutz
 -Theft protection System
 -système de protection de vol
 -Sistema de protección de robo

Only valid in relation with current engineering BOM

Scale	Format	ISO "E"	<input type="checkbox"/> Approval requirement	<input type="checkbox"/> Critical feature	Name	Sheet
-	A3		<input type="checkbox"/> ABE	<input type="checkbox"/> Major feature	SD TE 76P ATC	4
Hilti = registered trademark of Hilti Corporation, Schaan, LI Copyright reserved					Status	04.12.2013 Released
					Drawn	12.07.2013 FROMMAR
					Modified	12.07.2013 FROMMAR
					Checked	
					Document No.	350238 / C / 571919
					Material No.	330570

120V USA

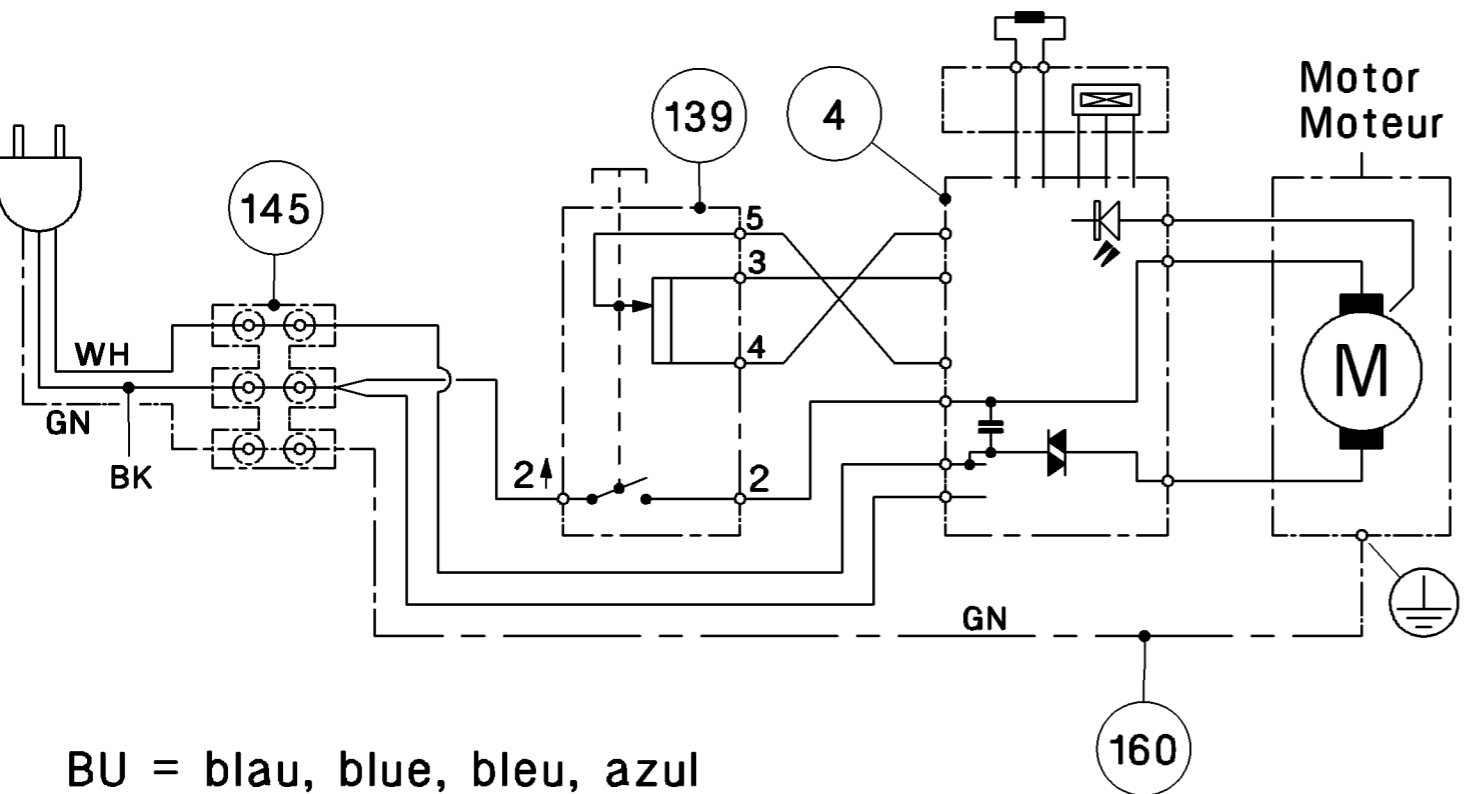
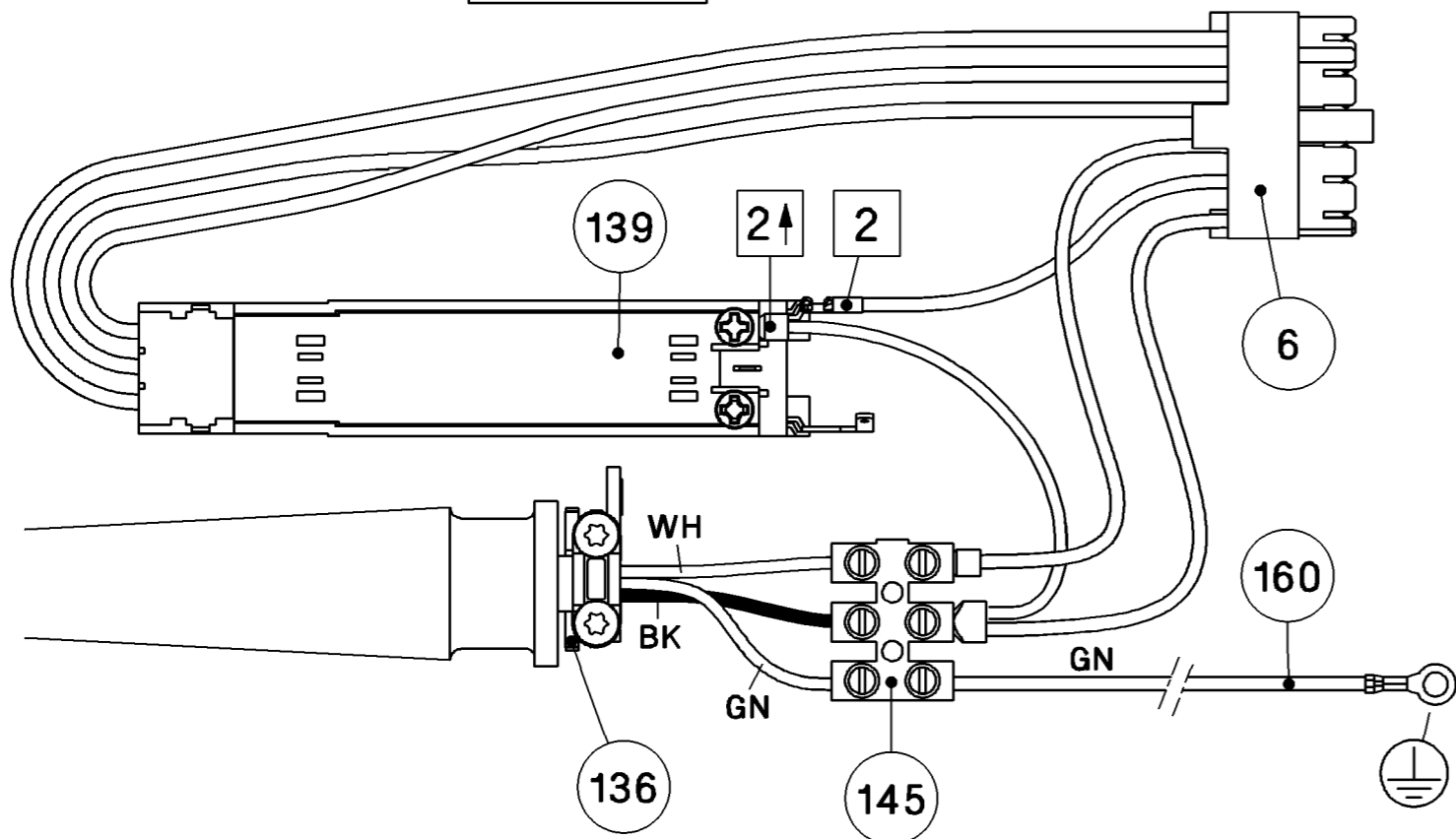
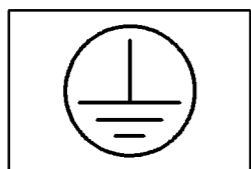

BU = blau, blue, bleu, azul
 GN = gruen, green, vert, verde
 WH = weiss, white, blanc, blanco
 BN = braun, brown, brun, marrón
 BK = schwarz, black, noir, negro

220V-240V
 100V-110V

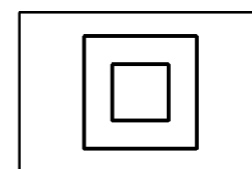

Masse/Dimensions in mm

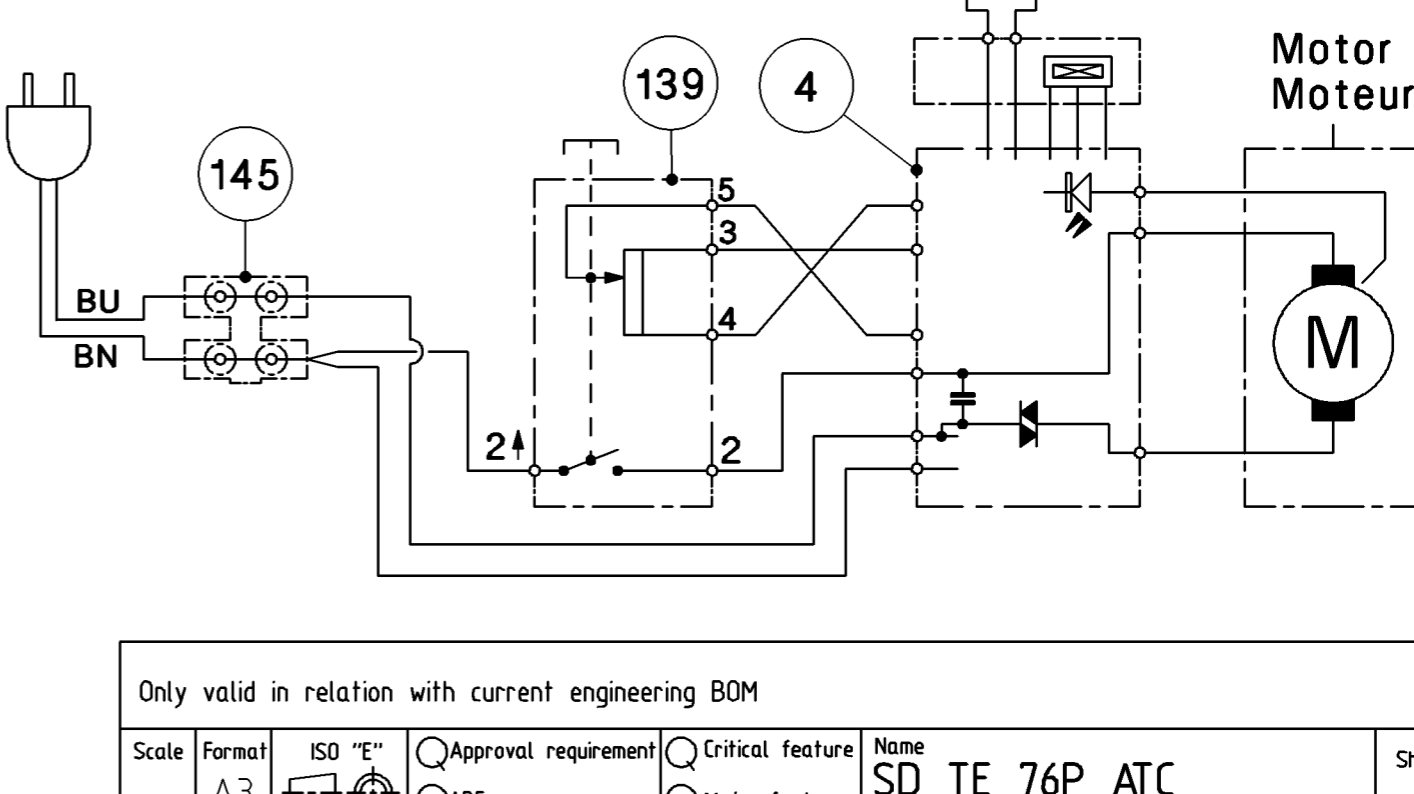
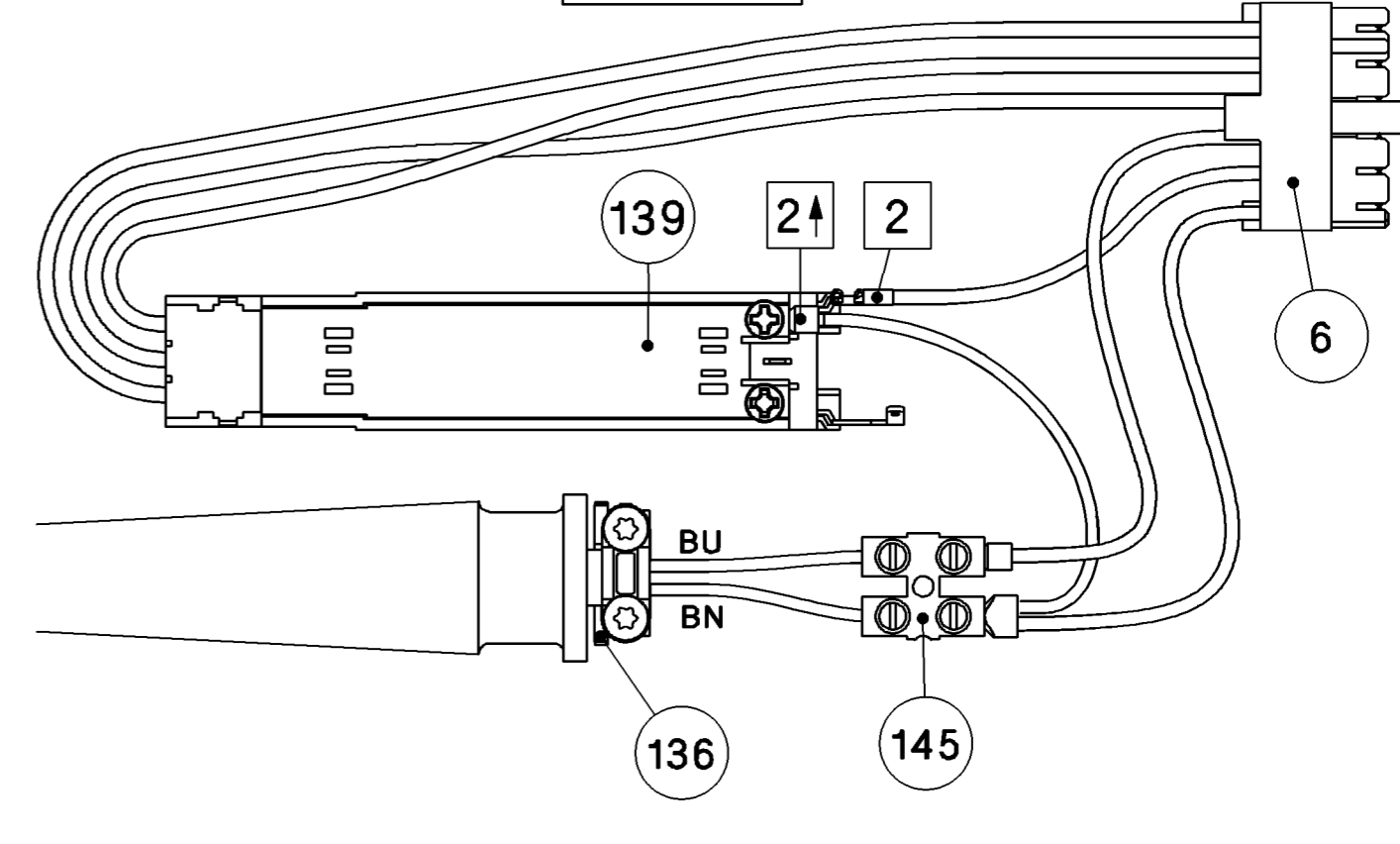

Only valid in relation with current engineering BOM

Scale	Format	ISO "E"	<input type="checkbox"/> Approval requirement	<input type="checkbox"/> Critical feature	Name	Sheet
-	A3		<input type="checkbox"/> ABE	<input type="checkbox"/> Major feature	SD TE 76P ATC	5
 Hilti = registered trademark of Hilti Corporation, Schaan, LI Copyright reserved					Status	04.12.2013 Released
					Drawn	12.07.2013 FROMMAR
					SZ TE 76P ATC	of 7
					Document No.	350238 / C / 571919
					Material No.	330570

	new	26mm
	replace	<14mm
	electronic stops	

	Pos 5	
	20 - 28 Nm	

	100V	0,28 - 0,34 Ω
	110-120V	0,39 - 0,47 Ω
	220-240V	1,59 - 1,93 Ω

	100V	14,5-17,7A
	110-120V	11,5 - 13,9A
	220-240V	5,7 - 6,9A

	100V	0,19 - 0,23 Ω
	110-120V	0,25 - 0,29 Ω
	220-240V	1,14 - 1,38 Ω

	I	194-200 rpm
	II	279-285 rpm

	100V	7,4 - 9,2A
	110-120V	6,3 - 7,8A
	220-240V	3,6 - 4,4A

Electrical safety test according VDE 0701 / 0702 or High voltage test according operation instruction SECUTEST	

Only valid in relation with current engineering BOM						
Scale 1:1	Format A3	ISO "E" 	<input type="checkbox"/> Approval requirement <input type="checkbox"/> ABE	<input checked="" type="checkbox"/> Critical feature <input checked="" type="checkbox"/> Major feature	Name SD TE 76P ATC SZ TE 76P ATC	Sheet 6 of 7
Hilti = registered trademark of Hilti Corporation, Schaan, LI Copyright reserved		Status	04.12.2013	Released	Document No. 350238 / C / 571919 Material No. 330570	
		Drawn	12.07.2013	FROMMAR		
		Modified	12.07.2013	FROMMAR		
		Checked				

8	7	>< 6	5	<>4	3	2	1																																				
F	<h3>Haftungsausschluss</h3> <p>Reparaturen am Gerät dürfen nur von einer entsprechend sachkundigen Fachkraft unter Berücksichtigung der gesetzlichen Vorschriften durchgeführt werden. Andernfalls besteht Unfall- und Verletzungsgefahr. Die entsprechenden Instruktionen bezüglich Pflege, Unterhalt und Reparaturen in den jeweiligen Bedienungsanleitungen sind strikte einzuhalten.</p>		<h3>Disclaimer</h3> <p>Tool repair must be performed only by qualified repair personnel knowledgeable about the specific tool and the legal requirements. Service, maintenance or repair performed by unqualified personnel could result in a risk of accidents and injury. The instructions with regard to service, maintenance and repair in the respective operating instructions must be strictly adhered to.</p>		<h3>免責條款</h3> <p>合格的機具維修人員必須具備特殊機具的知識，並符合法規的要求。由不合格的人員進行服務、保養或維修，可能會造成危險事故及傷害。必須嚴格遵守各項說明書中之服務、保養及維修的說明。</p>		<p>Masse/Dimensions in mm</p> <h3>Изключване на отговорността</h3> <p>Уреалт може да се ремонтира само от компетентен специалист при съблюдаване на нормативните разпоредби. В противен случай може да възникне опасност от нараняване или злополука. Трябва да се спазват стриктно съответните инструкции по отношение на техническо обслужване, поддръжка и ремонт, които са приведени в съответните ръководства за експлоатация.</p>																																				
E	<h3>Vyloučení záruky</h3> <p>Opravy náradí směji, s ohledem na zákonné předpisy, provádět náležitým způsobem jen odborně kvalifikovaní pracovníci. Jinak vzniká riziko úrazu a poškození. Pokyny ohledně ošetřování, údržby a oprav, uvedené v příslušných návodech k použití, musí být přesně dodrženy.</p>		<h3>Ansvarsfraskrivelse</h3> <p>Reparationer på apparatet skal altid udføres af en fagmand i overensstemmelse med de gældende regler og bestemmelser. I modsat fald er der risiko for ulykker og personskader. Anvisningerne på pleje, vedligeholdelse og reparationer, der er beskrevet i instruktionsbogen, skal altid overholdes.</p>		<h3>Αποποίηση ευθυνών</h3> <p>Επισκευές στη συσκευή επιτρέπεται να διενεργούνται μόνο από αντίστοιχα εκπαιδευμένα πρόσωπα λαμβάνοντας υπόψη τις νομικές διατάξεις. Διαφορετικά υπάρχει κίνδυνος για ατυχήματα και τραυματισμούς. Πρέπει να τηρούνται αυστηρά οι ισχύουσες οδηγίες που αναφέρονται στα εκάστοτε εργαλεία χρήσης όσον αφορά τη φροντίδα, τη συντήρηση και τις επισκευές.</p>		<h3>Exención de responsabilidad</h3> <p>Las reparaciones que se realicen en la herramienta sólo pueden ser efectuadas por expertos especializados conforme a las disposiciones legales. En caso contrario, existe el peligro de accidente o el riesgo de lesiones. Las indicaciones referentes al cuidado, al mantenimiento y a las reparaciones incluidas en los correspondientes manuales de instrucciones deben cumplirse estrictamente.</p>																																				
E	<h3>Vastutuse välistamine</h3> <p>Seadet tohivad parandada üksnes asjaomase ettevõtmistusega spetsialistid, kes peavad kinni seadusandlikest eeskirjadest. Nimetatud nõude eiramise tagajärjeks on vigastuste ja õnnetuste oht. Rangelt tuleb järgida iga seadme kasutusjuhendis toodud asjaomaseid hooldus-, korrashoiu- ja parandusjuhiseid</p>		<h3>Vastuulauseke</h3> <p>Laitteiden ja koneiden korjauksia saa tehdä vain ammattitaitoinen, näihin töihin koulutettu henkilö, ja toisssä on noudatettava lakisääteisiä määräyksiä. Muutoin onnettomuus- ja loukkaantumisvaara on olemassa. Käyttöohjeissa annettuja hoitoa, ylläpitoa ja korjauksia koskevia ohjeita on ehdottomasti noudatettava tarkasti.</p>		<h3>Limitation de responsabilité</h3> <p>Les réparations sur l'appareil doivent exclusivement être effectuées par une main-d'œuvre qualifiée et compétente, conformément aux prescriptions légales. À défaut de quoi, il y a risque d'accidents et de blessures corporelles. Les instructions correspondantes relatives au nettoyage, à l'entretien et aux réparations spécifiées dans les modes d'emploi respectifs doivent être rigoureusement respectées.</p>		<h3>Isključenje odgovornosti</h3> <p>Popravke na uređaju smiju izvoditi samo odgovarajući stručnjaci uzimajući u obzir zakonske propise. U suprotnom slučaju postoji opasnost od nezgoda i tjelesnih ozljeda. Strogo se valja pridržavati odgovarajućih uputa glede njege, održavanja i popravaka u pojedinim uputama za uporabu.</p>																																				
D	<h3>A felelősség kizárása</h3> <p>A szerszám javítását csak kifejezetten hozzáértő szakember végezheti a vonatkozó törvényes előírások betartásával. Ennek figyelmen kívül hagyása baleset- és sérülésveszélyt idéz elő. A mindenkorai kezelési utasítás szervizre, karbantartásra és javításra vonatkozó rendelkezéseit szigorúan be kell tartani.</p>		<h3>Esclusione di responsabilità</h3> <p>Le riparazioni dell'attrezzo devono essere eseguite esclusivamente da personale specializzato addestrato, osservando i relativi requisiti di legge. In caso contrario sussiste il pericolo di incidenti e di lesioni. Attenersi con precisione alle istruzioni relative alla cura, la manutenzione e la riparazione riportate nelle rispettive istruzioni d'uso.</p>		<h3>免責条項</h3> <p>本体の修理は、訓練を受けた修理スペシャリストのみが、適用されている法規に従って行うことができます。その他の方が修理しますと、怪我や事故の危険がともないます。取扱説明書に記述されている手入れ、保守および修理に関する指示を必ず遵守してください。</p>		<h3>보증제외</h3> <p>기기의 수리는 법규를 고려하여 전문 기술자만이 실시할 수 있습니다. 그렇게 하지 않으면 사고 및 부상의 위험이 있습니다. 해당 사용 설명서에 기재되어 있는 서비스, 유지보수 및 수리와 관련된 지침을 엄격하게 준수해야 합니다.</p>																																				
C	<h3>Atsakomybės apibrėžimas</h3> <p>Prietaisais gali būti taisomas tik atitinkama kvalifikacija turinčių specialistų atsizvelgiant į teisinius poįvarkius. Priešingu atveju yra pavojus patirti nelaimingą atsitikimą arba susižeisti. Privatu tiksliai laikytis atitinkamų priežiūros, aptarnavimo ir remonto instrukcijų, nurodytų atitinkamo prietaiso naudojimo instrukcijoje.</p>		<h3>Atbildības atsaukšana</h3> <p>Instrumenta remonu drīkst veikt tikai atbilstoši kvalificēts personāls, ievērojot spēkā esošās tiesību normas. Citādā gadījumā pastāv negadījumu risks un risks gūt traumas. Stingri jāievēro atbilstoši attiecīgo lietošanas instrukciju norādījumi, kuri attiecas uz instrumentu kopšanu, uzturēšanu kārtībā un remontu.</p>		<h3>Disclaimer</h3> <p>Reparaties aan het apparaat mogen alleen worden uitgevoerd door gekwalificeerd en deskundig personeel, met inachtneming van de wettelijke voorschriften. Wordt hier niet aan voldaan, dan kan dit leiden tot ongevallen of letsel. Men dient zich strikt te houden aan de instructies inzake verzorging, onderhoud en reparaties in de betreffende gebruiksaanwijzingen.</p>		<h3>Ansvarsfraskrivelse</h3> <p>Reparasjon av maskinen skal kun foretas av sakkynndig fagperson. Lovfestede krav må følges under dette arbeidet. I motsatt fall oppstår fare for ulykker og personskade. De tilhørende instruksjonene vedrørende pleie, vedlikehold og reparasjon i de tilhørende bruksanvisningene må følges nøye.</p>																																				
B	<h3>Wyłączenie odpowiedzialności cywilnej</h3> <p>Naprawy urządzenia mogą być przeprowadzane wyłącznie przez autoryzowanego serwisanta z uwzględnieniem obowiązujących przepisów prawnych. W przeciwnym razie istnieje zagrożenie spowodowania wypadku i obrażeń. Należy dokładnie przestrzegać zaleceń z poszczególnych instrukcji obsługi dotyczących pielęgnacji, utrzymywania w stanie sprawności oraz napraw.</p>		<h3>Exclusão de responsabilidade</h3> <p>As reparações no aparelho devem ser efectuadas apenas por pessoal técnico especializado, sob consideração das prescrições legais. Caso contrário, existe perigo de acidente e ferimentos. As respectivas instruções relativas à conservação, manutenção e reparações que constam no respectivo manual de instruções devem ser rigorosamente respeitadas.</p>		<h3>Исключение ответственности</h3> <p>Ремонт аппарата должен выполняться только квалифицированным специалистом при условии соблюдения предписаний, установленных законом. В противном случае возможна угроза несчастного случая или травмирования. Следует неукоснительно выполнять инструкции по уходу, содержанию и ремонту аппарата, приведенные в соответствующих руководствах по эксплуатации.</p>		<h3>Vylúčenie záruky</h3> <p>Opravy náradia smú, s ohľadom na zákonné predpisy, vykonávať náležitým spôsobom len odborné kvalifikovaní pracovníci. Inak vzniká riziko úrazu a poškodenia. Pokyny týkajúce sa ošetrovania, údržby a opráv, uvedené v príslušných návodoch na používanie, musia byť presne dodržané.</p>																																				
B	<h3>Isključitev odgovornosti</h3> <p>Popravila lahko izvajajo le ustrezno usposobljeni strokovnjaki ob upoštevanju zakonskih predpisov. V nasprotnem primeru obstaja nevarnost nesreč in poškodb. Strogo je treba upoštevati ustrezna navodila glede nege, vzdrževanja in popravila iz posameznih navodil za uporabo.</p>		<h3>Friskrivning från ansvar</h3> <p>Reparationer på detta verktyg får endast utföras av fackman, och gällande lagar och regler måste följas. I annat fall finns risk för olyckor och skador. Instruktionerna om skötsel, underhåll och reparationer i respektive bruksanvisning måste följas strikt.</p>		<div style="text-align: right;">☑</div>																																						
A	<h3>Clauze de exonerare</h3> <p>Repararea maşinii (sculei) trebuie efectuată doar de către personal calificat pentru reparații, care posedă cunoștințe despre mașina respectivă și cerințele legale. Activitățile de depanare, întreținere și reparare efectuate de personal necalificat pot duce la risc de accidentări și vătămări. Trebuie respectate cu strictețe toate instrucțiunile de depanare, întreținere și reparare din manualele de utilizare respective.</p>				<div style="border: 1px solid black; padding: 5px;"> <p>Only valid in relation with current engineering BOM</p> <table border="1" style="width: 100%; border-collapse: collapse;"> <tr> <td style="width: 5%;">Scale</td> <td style="width: 5%;">Format</td> <td style="width: 10%;">ISO "E"</td> <td style="width: 15%;"> <input type="checkbox"/> Approval requirement <input type="checkbox"/> ABE </td> <td style="width: 15%;"> <input checked="" type="checkbox"/> Critical feature <input checked="" type="checkbox"/> Major feature </td> <td style="width: 20%;">Name</td> <td style="width: 10%;">Sheet</td> </tr> <tr> <td>-</td> <td>A3</td> <td></td> <td></td> <td></td> <td>SD TE 76P ATC</td> <td>7</td> </tr> <tr> <td colspan="3" rowspan="2" style="text-align: center;">HILTI</td> <td>Status</td> <td>04.12.2013</td> <td>Released</td> <td rowspan="2" style="text-align: center; vertical-align: middle;">SZ TE 76P ATC</td> </tr> <tr> <td>Drawn</td> <td>12.07.2013</td> <td>FROMMAR</td> </tr> <tr> <td colspan="3" rowspan="2" style="text-align: center;">Hilti = registered trademark of Hilti Corporation, Schaan, LI Copyright reserved</td> <td>Modified</td> <td>12.07.2013</td> <td>FROMMAR</td> <td>Document No. 350238 / C / 571919</td> </tr> <tr> <td>Checked</td> <td></td> <td></td> <td>Material No. 330570</td> </tr> </table> </div>		Scale	Format	ISO "E"	<input type="checkbox"/> Approval requirement <input type="checkbox"/> ABE	<input checked="" type="checkbox"/> Critical feature <input checked="" type="checkbox"/> Major feature	Name	Sheet	-	A3				SD TE 76P ATC	7	HILTI			Status	04.12.2013	Released	SZ TE 76P ATC	Drawn	12.07.2013	FROMMAR	Hilti = registered trademark of Hilti Corporation, Schaan, LI Copyright reserved			Modified	12.07.2013	FROMMAR	Document No. 350238 / C / 571919	Checked			Material No. 330570		
Scale	Format	ISO "E"	<input type="checkbox"/> Approval requirement <input type="checkbox"/> ABE	<input checked="" type="checkbox"/> Critical feature <input checked="" type="checkbox"/> Major feature	Name	Sheet																																					
-	A3				SD TE 76P ATC	7																																					
HILTI			Status	04.12.2013	Released	SZ TE 76P ATC																																					
			Drawn	12.07.2013	FROMMAR																																						
Hilti = registered trademark of Hilti Corporation, Schaan, LI Copyright reserved			Modified	12.07.2013	FROMMAR	Document No. 350238 / C / 571919																																					
			Checked			Material No. 330570																																					
8	7	>< 6	5	4	3	2	1																																				